



281KW

EU Stage II

6 cylinders

FOGO GENSET ENGINE

F0103-0322

Engineered for superior performance, the F0103-0322 delivers 250 kWe of prime power with advanced turbocharged technology. This 6-cylinder 10.34L diesel engine combines high efficiency with robust construction for demanding power generation needs.

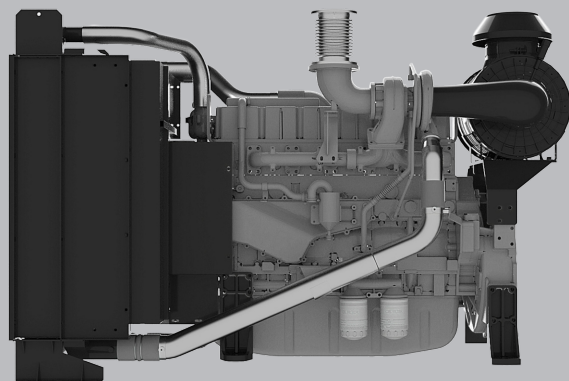

MAIN TECHNICAL PARAMETERS

Number of cylinders	6
Configuration	Vertical, in-line
Aspiration	Turbocharged, air/air intercooled
Combustion system	Direct injection
Compression ratio	16.8:1
Bore x Stroke	123mm x 146mm
Displacement	10.34L
Rotation	Counterclockwise (viewed from the flywheel end)
Fuel system	Mechanical
Governor	Electronic
Stability at constant load [ISO 8528-5 Class G3]	± 0.5 %
50/60Hz switchable operation	YES
Electric system	24V
Tropical Radiator mounted on the engine	Ambient 50°C
Flywheel Housing	SAE1 /14"
Lubrication Oil capacity	30L
Coolant capacity	65L
Emission class compliance	EU Stage II

THE ENGINE PERFORMANCE

GROSS ENGINE OUTPUT 50HZ

PRP	281 kWm
ESP	309 kWm

TYPICAL GENERATOR OUTPUT 50HZ

PRP	255 kW _e
PRP	318 kVA
ESP	350 kVA

FUEL CONSUMPTION

STANDBY [ESP]	213.0 g/kWh	74.9 L/h
PRIME [PRP]	199.0 g/kWh	67.4 L/h
75% PRP [prime]	200.7 g/kWh	33.8 L/h
50% PRP [prime]	197.6 g/kWh	50.0 L/h
HVO synthetic fuel acceptance		

KEY FEATURES

MAIN FEATURES

- ✓ Compact design
- ✓ Good power density
- ✓ Durability
- ✓ Easy service & maintenance
- ✓ Low fuel consumption
- ✓ Wide selection of optional equipment
- ✓ Low noise
- ✓ Tailored cooling pack

STANDARD SCOPE OF SUPPLY

- ✓ Cast iron cylinder block c/w separate cast iron cylinder head
- ✓ Aluminum alloy pistons with gallery oil cooling
- ✓ Automatic belt tensioner, Lift eyes, Fixed front suspension
- ✓ Radiator with mechanical pusher fan, thermostatically controlled
- ✓ Large capacity oil pan, spin-on full-flow oil filter, oil dipstick
- ✓ Fuel injection pump for high inject pressure, P-type injectors
- ✓ Duplex fine fuel filter c/w water separator
- ✓ Air inlet preheater
- ✓ Side mounted turbocharger
- ✓ Rear mounted air filter with restriction indicator
- ✓ 24V DC electric system with 9kW starter
- ✓ 55A charging alternator
- ✓ Heat isolated exhaust manifold

DIMENSIONS & WEIGHT

DIMENSIONS & WEIGHT

Including radiator (dry weight)

2088
Length (mm)

1130
Width (mm)

1392
Height (mm)

1186
Weight (kg)

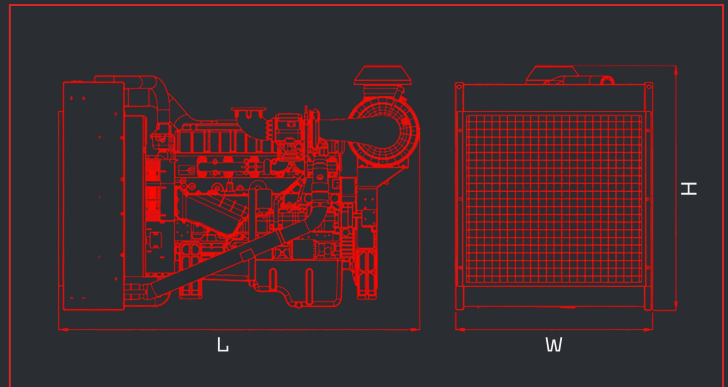

POWER DEFINITIONS:

ESP = STANDBY POWER

According to ISO8528 is maximum power available during variable electrical power sequence up to 200h of operation per year, permissible output over 24h operation should not exceed 70% ESP

PRP = PRIME POWER

According to ISO8528 is maximum power engine can deliver continuously for unlimited number of hours per year permissible output over 24h operation should not exceed 70% PRP

FOGO.PL

INTERNATIONAL WARRANTY

PRIME POWER
2 years with
no hours limitations

STANDBY POWER
4 years or max. 1000 hrs
not more than 300 hrs per year