



815KW

Stage III

6 cylinders

# FOGO GENSET ENGINE

## F0281-0913

Engineered for superior performance, the F0281-0913 delivers 730 kWe of prime power with advanced turbocharged technology. This 6-cylinder 28.14L diesel engine combines high efficiency with robust construction for demanding power generation needs.

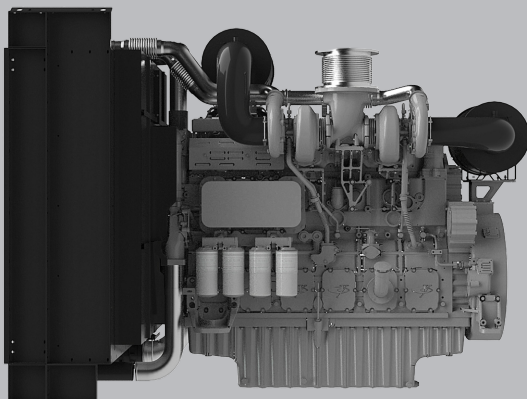

### MAIN TECHNICAL PARAMETERS

Number of cylinders	6
Configuration	Vertical, in-line
Aspiration	Turbocharged and intercooled
Combustion system	Direct injection
Compression ratio	14:1
Bore x Stroke	175mm x 195mm
Displacement	28.14L
Rotation	Counterclockwise (viewed from the flywheel end)
Fuel system	Electronic pump injectors
Governor	Electronic
Stability at constant load [ISO 8528-5 Class G3]	≤ +/- 0.5 %
50/60Hz switchable operation	NO
Electric system	24V
Tropical Radiator mounted on the engine	Ambient 50°C
Flywheel Housing	SAE0 /18"
Lubrication Oil capacity	115L
Coolant capacity	165L
Emission class compliance	Stage III

# THE ENGINE PERFORMANCE

## GROSS ENGINE OUTPUT 50HZ

PRP/DCP	815 kWm
ESP	897 kWm

## TYPICAL GENERATOR OUTPUT 50HZ

PRP/DCP	730 kWe
PRP/DCP	913 kVA
ESP	1000 kVA

## FUEL CONSUMPTION

STANDBY [ESP]	198.3 g/kWh	212.9 L/h
PRIME [PRP/DCP]	196.9 g/kWh	192.2 L/h
75% PRP/DCP [prime]	196.9 g/kWh	96.3 L/h
50% PRP/DCP [prime]	194.4 g/kWh	142.3 L/h
HVO synthetic fuel acceptance		

# KEY FEATURES

## MAIN FEATURES

- ✓ Compact design
- ✓ Good power density
- ✓ Good load acceptance
- ✓ Durability
- ✓ Easy service & maintenance
- ✓ Low fuel consumption
- ✓ Wide selection of optional equipment
- ✓ Low noise
- ✓ Tailored cooling pack

## STANDARD SCOPE OF SUPPLY

- ✓ Cast iron cylinder block c/w separate cast iron cylinder head
- ✓ Aluminum alloy pistons with gallery oil cooling
- ✓ Automatic belt tensioner, Lift eyes, Fixed front suspension
- ✓ Radiator with mechanical pusher fan, thermostatically controlled
- ✓ Large capacity oil pan, spin-on full-flow oil filter, oil dipstick
- ✓ Electronic pump-injectors, Electronic governor
- ✓ Duplex fine fuel filter c/w water separator
- ✓ Air inlet preheater
- ✓ Side mounted turbocharger
- ✓ Rear & top mounted air filter with restriction indicator
- ✓ 24V DC electric system with two starters 7.5kW each
- ✓ 70A charging alternator
- ✓ Heat isolated exhaust manifold

# DIMENSIONS & WEIGHT

## DIMENSIONS & WEIGHT

Including radiator (dry weight)

**2817**  
Length (mm)

**1750**  
Width (mm)

**1992**  
Height (mm)

**3810**  
Weight (kg)

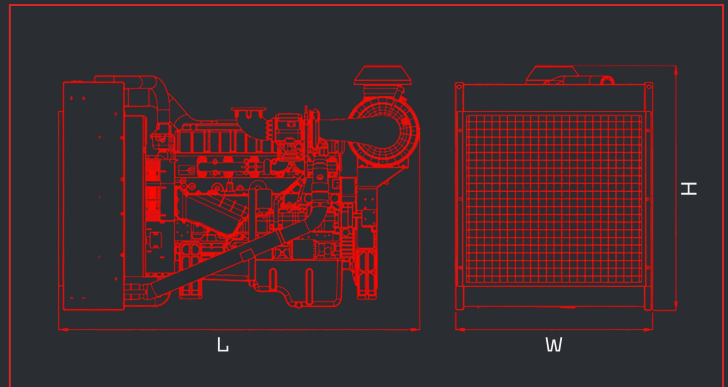

### POWER DEFINITIONS:

ESP = STANDBY POWER

PRP = PRIME POWER

DCP = DATA CENTER POWER

According to ISO8528 is maximum power available during variable electrical power sequence up to 200h of operation per year, permissible output over 24h operation should not exceed 70% ESP

According to ISO8528 is maximum power engine can deliver continuously for unlimited number of hours per year permissible output over 24h operation should not exceed 70% PRP

It corresponds to the data center power (DCP) of GB/T 2820 and ISO 8528, and refers to the maximum power that the engine can provide for variable or continuous electrical loads under conditions of unlimited operating time, with the maintenance intervals and procedures being carried out as prescribed by FOGO. The generator unit is only applicable to the backup power supply of the data center. Prolonged operation at load in parallel with a utility is not permitted.

**FOGO.PL**

**INTERNATIONAL  
WARRANTY**

**PRIME / DATA CENTER POWER**  
2 years with  
no hours limitations

**STANDBY POWER**  
4 years or max. 1000 hrs  
not more than 300 hrs per year